

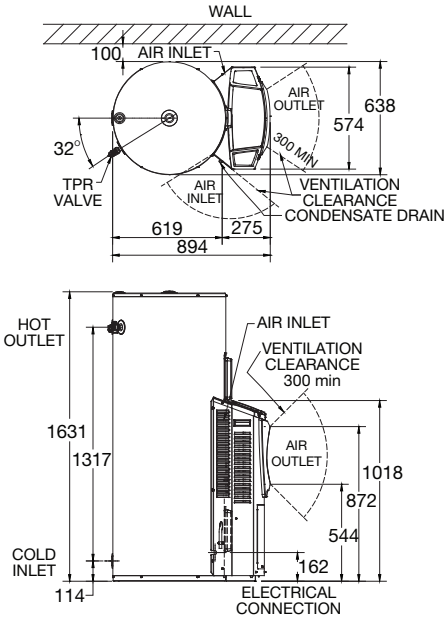

Features & Benefits

- Multi-pass heating – Heats the water by passing the water through the heat exchanger multiple times
- Back up element - for heating water in frost conditions
- One person plumbing installation – refrigeration mechanic not required
- LED display to indicate operating status
- Eligible for STCs⁵
- 5 year cylinder warranty¹



MODEL	551325
Storage Capacity (L)	325
Element Rating (kW)	3.6
Relief Valve Pressure (kPa)	1000
Expansion Control Valve (kPa)	850
Max Water Supply Pressure:	
with ECV (kPa)	680
without ECV (kPa)	800
Water Connections	Rp 3/4
Approx. Weight (Empty) kg	130

