

5L Compact Storage Electric Water Heater



Electronically controlled storage heater, with stainless steel tank designed to ensure quick and easy access to hot water. It is great for installation next to a sink in a laundry, bathroom, or kitchen. This electronic storage hot water heater is energy efficient and compact. The stainless-steel inner tank is resistant to corrosion, with a quick heating time of just 5.5min+ for a full tank.

- **Stainless Steel Tank**
 - + Resistant to corrosion
 - + No need to change anode regularly
- **Comfortable Temperature Control**
 - + With smooth temperature range between 23-70°C
- **Energy Efficient**
 - + With very low energy losses
- **Available in under sink & over sink design**
- **For single point of use/outlet**
- **Must be installed with Bromic Mixer Tap included**

Applications



Kitchen sink



Bathroom sink/basin

Pressurised connection to vented mixer tap provided.

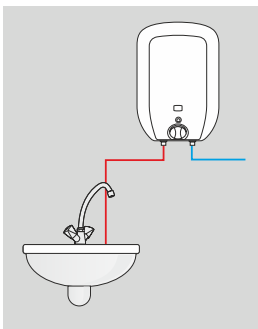

Over Sink

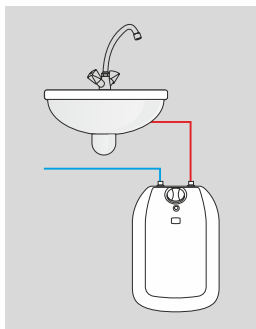

Under Sink

Quick Heating Time



- With immersion heater of 2000W
- Heats 5L in 5.5min at 30°C temperature rise

Dimensions

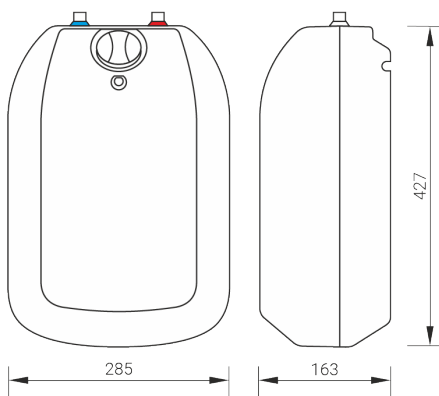

Vented Mixer Tap Included



*Must be installed with Bromic tapware provided.

5L Range Specifications

| Model | HF-UH5 | HF-OH5 |
|--------------------------------|---|---|
| Product No. | 2850001 | 2850002 |
| Mount | Under Sink | Over Sink |
| Type | Vented Storage | Vented Storage |
| Voltage, V | 240V | 240V |
| Rated Power, kW | 2000 | 2000 |
| Rated Current, A | 8.3 - 9.1 | 8.3 - 9.1 |
| Max Inlet Pressure Rating, kPa | 600 | 600 |
| Temperature Range, °C | 23° - 70° | 23° - 70° |
| Dimensions (H x W x D) mm | 427 x 285 x 163 | 427 x 285 x 163 |
| Weight, kg | 4.5 | 4.5 |
| IP Rating | IP24 | IP24 |
| Water Connections | Cold = G 1/2" Male Hot = G 1/2" Male | Cold = G 1/2" Male Hot = G 1/2" Male |
| Tank Material | Stainless Steel | Stainless Steel |
| Approvals | WM 40268 (AS 3498) | WM 40268 (AS 3498) |

Features

- Stainless steel tank
- Pressurised system
- Electronically controlled

