

DESCRIPTION

Chelsea straight basin mixer without waste

PRODUCT CODE

CH19



FEATURES

Dimensions - W 48 x H 160 D 156 mm

- Brass body, chrome finish
- 1.22 kg
- Tap valves available with traditional screw down valves or with quarter turn valves. For quarter turn taps simply add 'QT' to the product code.
- White ceramic tap handle.
- Works with both low and high pressure –
Supplied with flow straightener - this is for use with low water pressure, and neoperl aerator - this is for use with high water pressure.
- 2 star WELS rating

TECHNICAL DRAWINGS

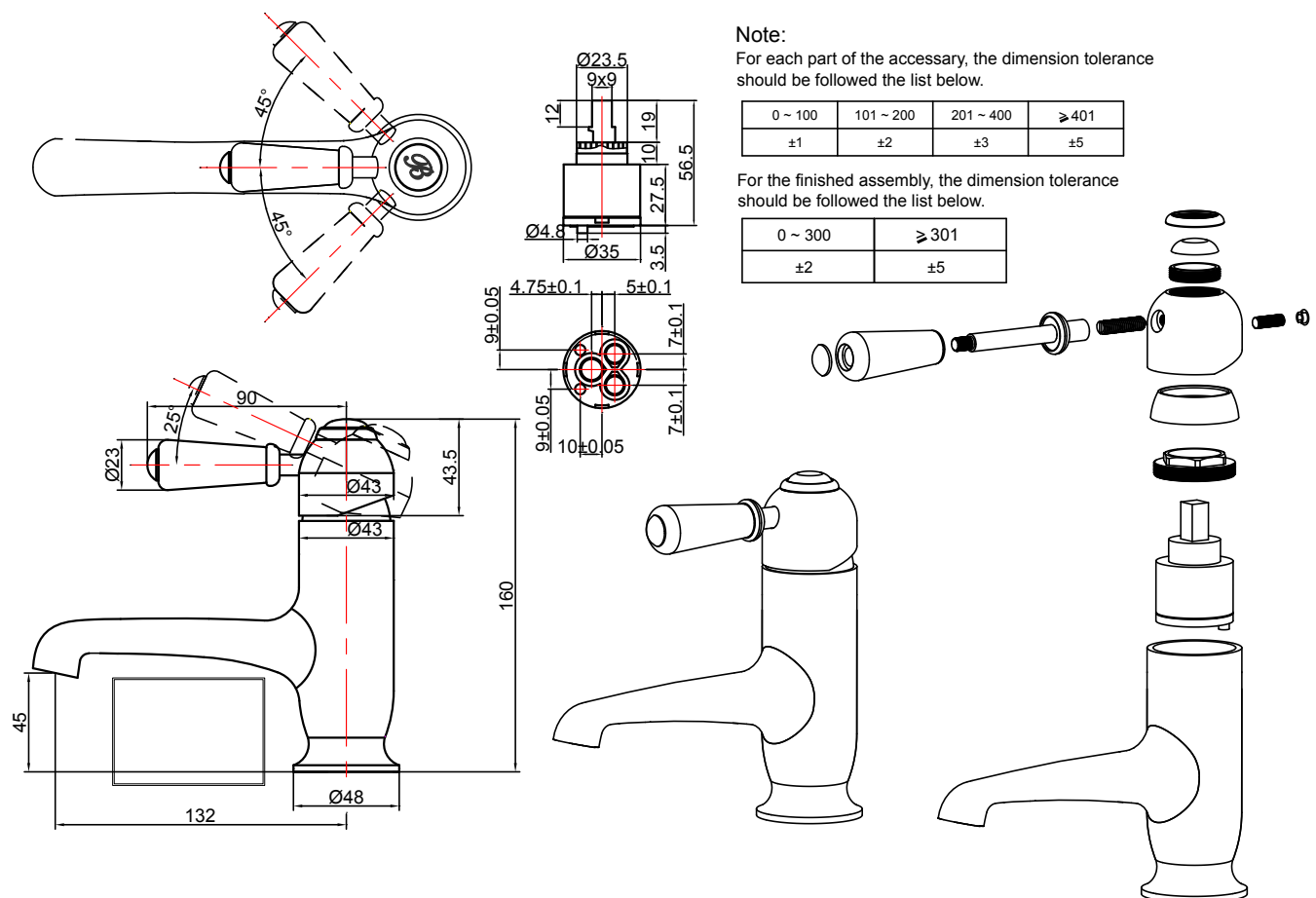

NOTES

Drawing indicates the technical measurement only and is not a reflection of how the unit will look. Sizes are nominal only. All drawings in millimeters. Drawings not to scale. November 2019.