

# Electric perfection

Introducing the Rinnai ES Series Electric Fire range; the ultimate in electric fires. Using cutting edge technology and innovation to provide instant heat and a hyperrealistic fireplace to your living space.

The Rinnai ES Series is the outstanding result of extensive research and development, meticulous attention to detail, and the highest standard of quality. With a host of unique and innovative features, these appliances are unrivaled in their class.

The Rinnai ES Series provides a complete range of options to create the ultimate fireplace which will transform your home, adding a touch of luxury that is perfectly tailored to reflect your own unique style.

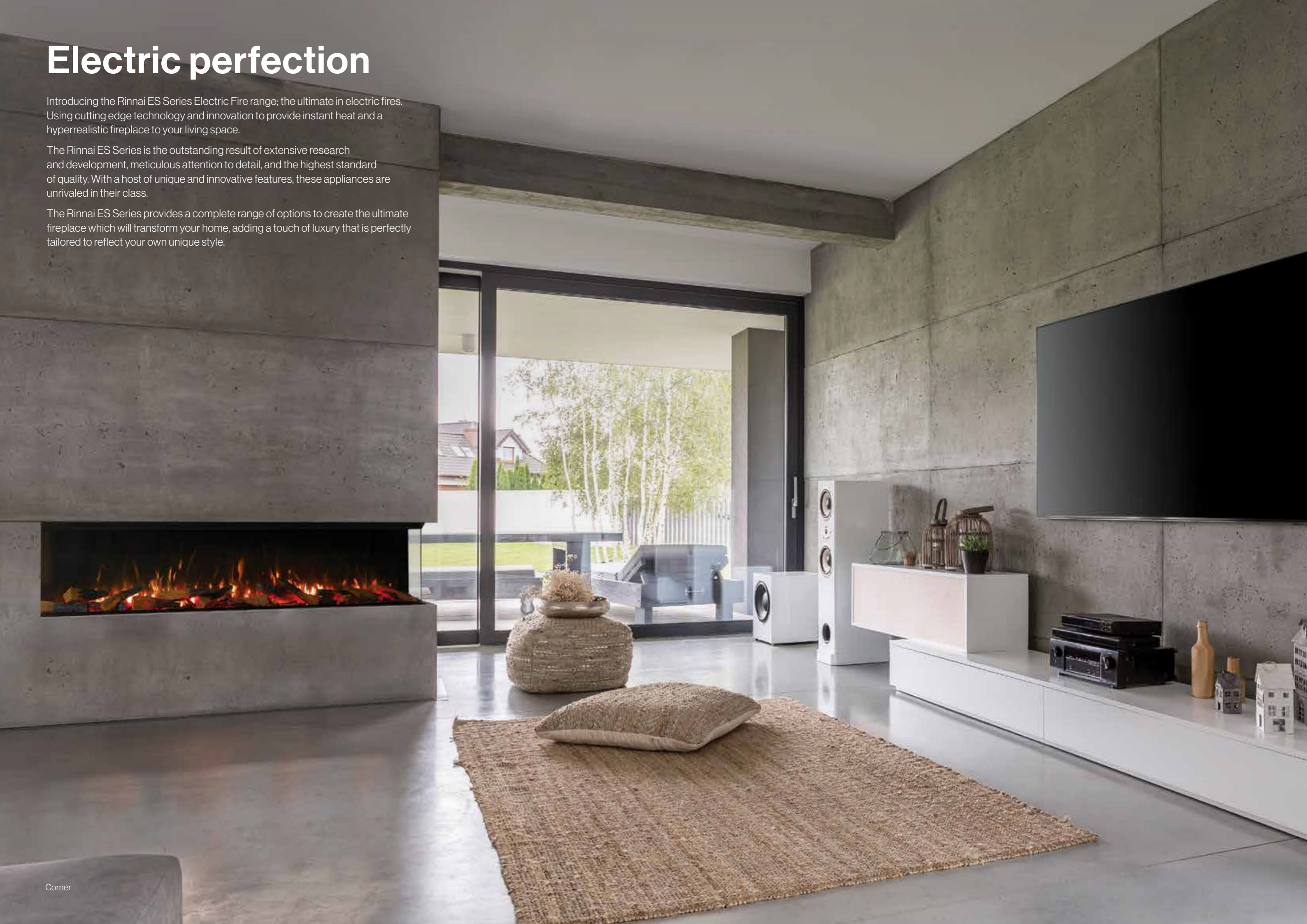

# ES 1000



## ES 1000

Add luxury to your living space with the ES 1000, the ultimate home investment. The ES 1000 is the smallest of our landscape electric fires at 1 metre in length. With the options of inset, panoramic (3 sided) or corner (left or right) aspect, you will be spoilt for choice when creating your perfect fireplace.

## Features

- 548 x 1030 x 296mm (dimensions H x W x D)
- Convenient multiple control options (manual or remote control)
- Easy to install
- Wall mountable (supplied with brackets)
- 6 pre-set TriLight themes (Autumn Campfire, Emberglow, Inferno, Noir, Fire & Ice, Nebular)
- Multi-option RGB flame and fuel bed colours with user preset options
- 7 day programmable timer with adaptive smart heating
- Heat output – 1.8kW (3 heating modes with cool blow function)
- Optimised heater position & minimal visible vents
- 3 independently controlled lighting effects
  - Flames – colour & brightness
  - Under fuel bed – colour & brightness
  - Above fuel bed – colour & brightness
- Open door/window detection
- Ultra-realistic glowing fuel bed with burning embers and customisable log layout



3 Sided



Corner

# Setting the scene

Our approach is to create beautiful, inspiring appliances that change the perception of a traditional electric fire.

Our unique TriLight technology provides multi-angled, fully customisable dynamic LED lighting to create multiple unique colour and tonal combinations to the flames and fuel bed. Each can work in harmony with one another or independently, creating one-of-a-kind combinations and an adaptive atmosphere, all at the touch of a button.

To provide an insight into the possibilities, all Rinnai ES Series electric range fires come with 6 programmed themes to highlight some of the fascinating lighting combinations that can be created. These are:

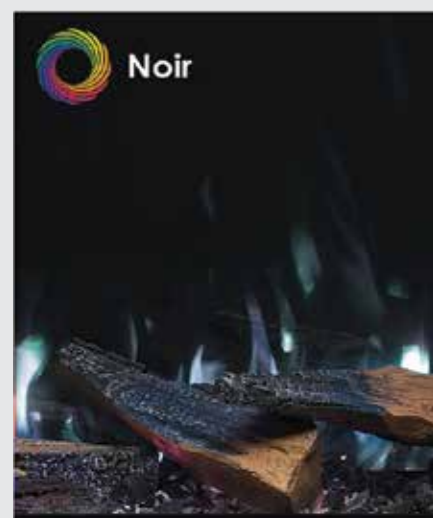
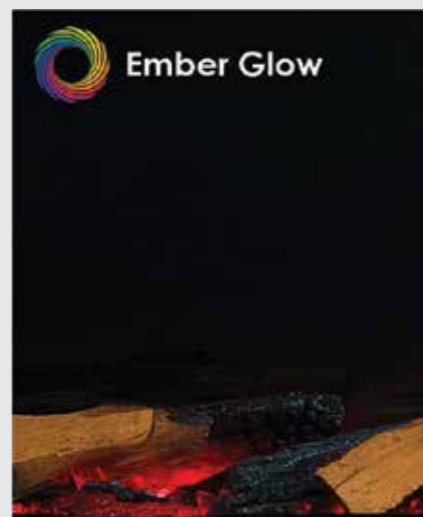

# Instant heat at your fingertips

Part of the Rinnai design ethos is to ensure that all appliances offer clear and simple controllability. Whilst functionality may have advanced and become more dynamic, we believe that intuitive interaction is paramount.

**The Rinnai ES fires can be conveniently controlled in two ways:**

- Manually using the multi-function panel discretely located on the appliance
- With the intuitive remote control handset

The quickstart heat option allows you to select low heat, high heat, or cool blow at the touch of a button. Adaptive smart heating allows you to schedule the exact time and date you wish to heat your room, automatically adjusting the environment to reach and maintain the desired temperature.



# Appliance Dimensions

(All dimensions are in millimetres.)

## ES 750

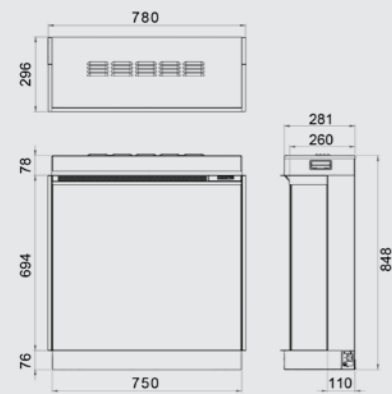

## ES 1000

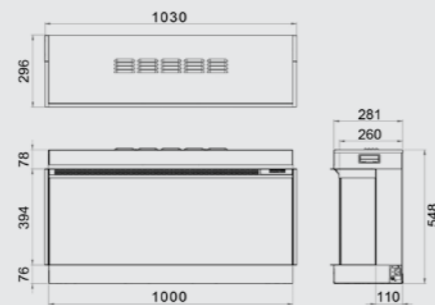

## ES 1300



## ES 1500



## ES 1800



## ES 2200





Inset

# Specifications

| Model                  | Unit     | ES750           | ES1000           | ES1300           | ES1500           | ES1800           | ES2200           |
|------------------------|----------|-----------------|------------------|------------------|------------------|------------------|------------------|
| Weight                 | kg       | 47.5            | 44.5             | 54.3             | 59.3             | 70.8             | 87               |
| Dimensions H x W x D   | mm       | 848 x 780 x 296 | 548 x 1030 x 296 | 548 x 1330 x 296 | 548 x 1530 x 296 | 548 x 1830 x 296 | 548 x 2230 x 296 |
| Supply Voltage         | VAC / Hz | 230-240 / 50    | 230-240 / 50     | 230-240 / 50     | 230-240 / 50     | 230-240 / 50     | 230-240 / 50     |
| Three pin plug type    | Amp      | 10              | 10               | 10               | 10               | 10               | 10               |
| Length of power lead   | mm       | 1600            | 1600             | 1600             | 1600             | 1600             | 1600             |
| Max. Power Consumption | W        | 2000            | 2000             | 2000             | 2000             | 2000             | 2000             |
| Power for Flame Effect | W        | 28              | 40               | 50               | 52               | 62               | 72               |

|                    |                     |
|--------------------|---------------------|
| <b>Heat Output</b> | <b>0.9 - 1.8 kW</b> |
|--------------------|---------------------|

| Auxiliary Electricity Consumption | W    |
|-----------------------------------|------|
| At Nominal Heat Output            | 12.5 |
| At Minimum Heat Output            | 12   |
| In Standby Mode                   | 1.1  |

| Type of Heat Output / Room Temperature Control      | Yes / No |
|---|----------|
| With electronic room temperature control            | Yes      |
| Electronic room temperature control plus day timer  | Yes      |
| Electronic room temperature control plus week timer | Yes      |

| Other Control Options                                | Yes / No |
|--|----------|
| Room temperature control, with open window detection | Yes      |
| With distance control option                         | Yes      |
| With adaptive start control                          | Yes      |

## Warranty

|             | Product Group        | Firebox |         | All other parts |         |
|-------------|----------------------|---------|---------|-----------------|---------|
|             |                      | Parts   | Labour  | Parts           | Labour  |
| Residential | Electric Fire Heater | 5 Years | 2 Years | 2 Years         | 2 Years |