

Electric perfection

Introducing the Rinnai ES Series Electric Fire range; the ultimate in electric fires. Using cutting edge technology and innovation to provide instant heat and a hyperrealistic fireplace to your living space.

The Rinnai ES Series is the outstanding result of extensive research and development, meticulous attention to detail, and the highest standard of quality. With a host of unique and innovative features, these appliances are unrivaled in their class.

The Rinnai ES Series provides a complete range of options to create the ultimate fireplace which will transform your home, adding a touch of luxury that is perfectly tailored to reflect your own unique style.

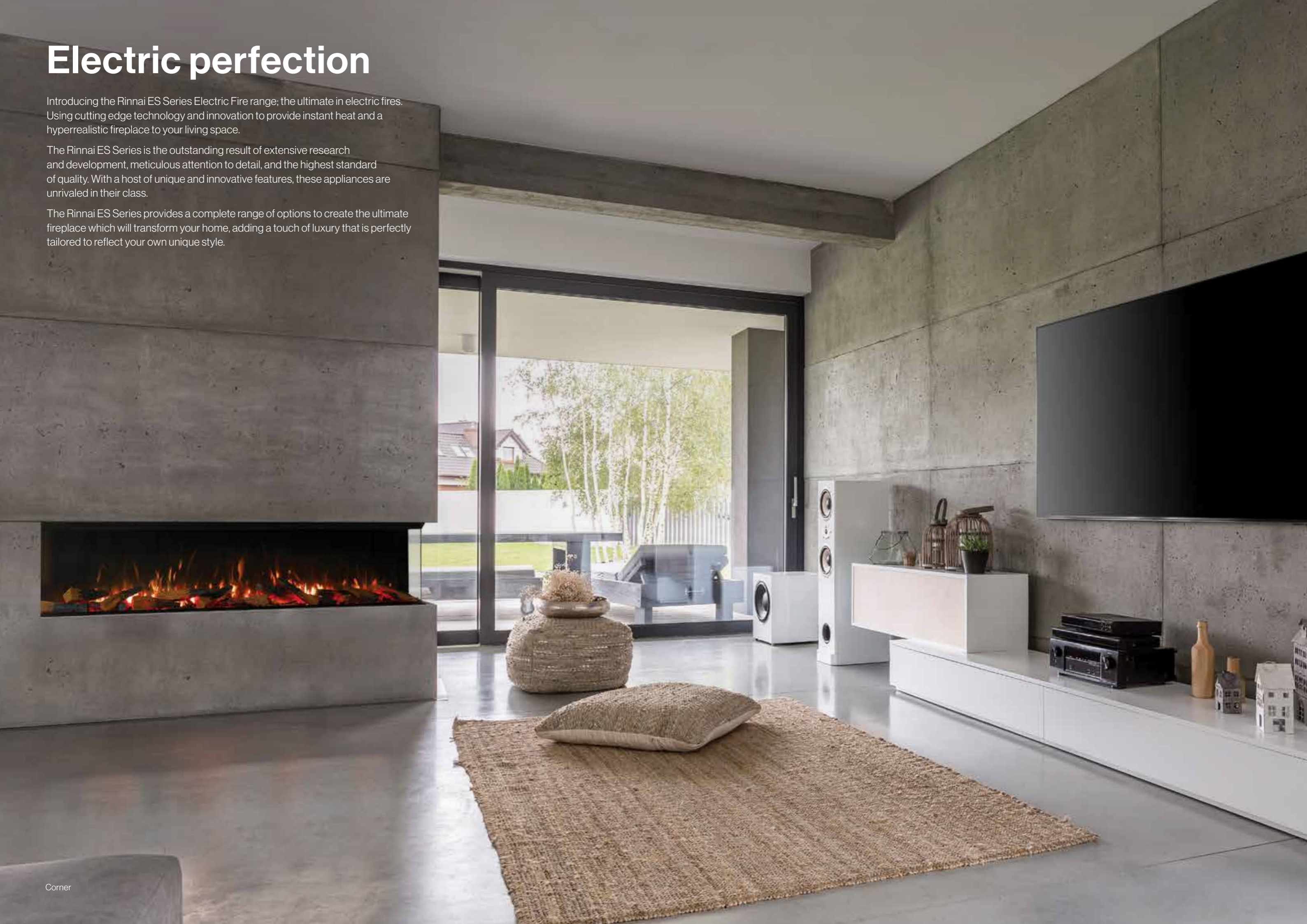

ES 2200



Inset

ES 2200

With the ES 2200 you have the largest fire in our range, at a stunning 2.2 metres in length. As impressive as it is, you are still in control of every aspect of the fire, from the speed, colour and brightness of the entrancing flames, to the enchanting crackling sounds of burning logs.

Features

- 548 x 2230 x 296mm (dimensions H x W x D)
- Wall mountable (supplied with brackets)
- 6 pre-set TriLight themes (Autumn Campfire, Emberglow, Inferno, Noir, Fire & Ice, Nebular)
- Multi-option RGB flame and fuel bed colours with user preset options
- Optimised heater position & minimal visible vents
- 7 day programmable timer with adaptive smart heating
- Open door/window detection
- 3 independently controlled lighting effects
 - Flames – colour & brightness
 - Under fuel bed – colour & brightness
 - Above fuel bed – colour & brightness
- Heat output – 1.8kW (3 heating modes with cool blow function)
- Convenient multiple control options (manual or remote control)
- Ultra-realistic glowing fuel bed with burning embers and customisable log layout
- Easy to install



3 sided

Setting the scene

Our approach is to create beautiful, inspiring appliances that change the perception of a traditional electric fire.

Our unique TriLight technology provides multi-angled, fully customisable dynamic LED lighting to create multiple unique colour and tonal combinations to the flames and fuel bed. Each can work in harmony with one another or independently, creating one-of-a-kind combinations and an adaptive atmosphere, all at the touch of a button.

To provide an insight into the possibilities, all Rinnai ES Series electric range fires come with 6 programmed themes to highlight some of the fascinating lighting combinations that can be created. These are:

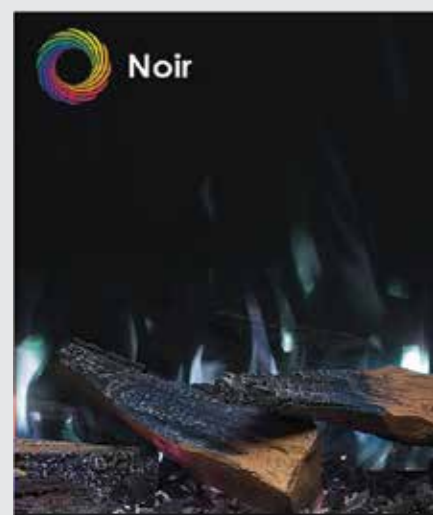
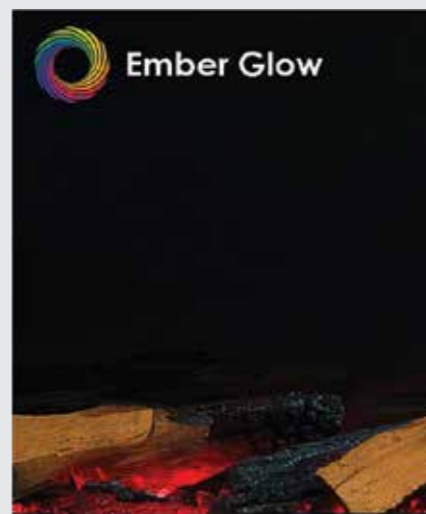

Instant heat at your fingertips

Part of the Rinnai design ethos is to ensure that all appliances offer clear and simple controllability. Whilst functionality may have advanced and become more dynamic, we believe that intuitive interaction is paramount.

The Rinnai ES fires can be conveniently controlled in two ways:

- Manually using the multi-function panel discretely located on the appliance
- With the intuitive remote control handset

The quickstart heat option allows you to select low heat, high heat, or cool blow at the touch of a button. Adaptive smart heating allows you to schedule the exact time and date you wish to heat your room, automatically adjusting the environment to reach and maintain the desired temperature.



Appliance Dimensions

(All dimensions are in millimetres.)

ES 750

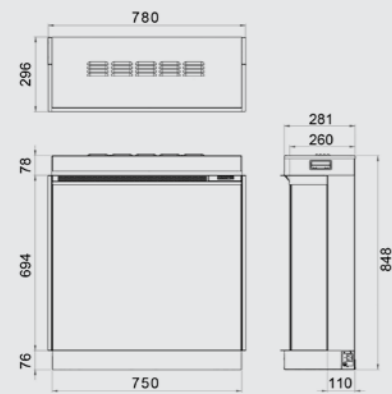

ES 1000

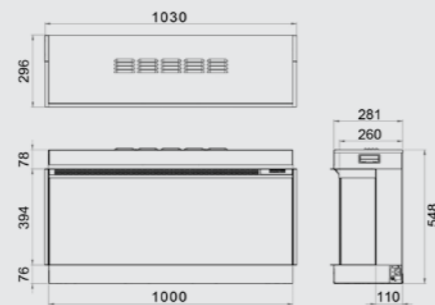

ES 1300



ES 1500



ES 1800



ES 2200





Inset

Specifications

Model	Unit	ES750	ES1000	ES1300	ES1500	ES1800	ES2200
Weight	kg	47.5	44.5	54.3	59.3	70.8	87
Dimensions H x W x D	mm	848 x 780 x 296	548 x 1030 x 296	548 x 1330 x 296	548 x 1530 x 296	548 x 1830 x 296	548 x 2230 x 296
Supply Voltage	VAC / Hz	230-240 / 50	230-240 / 50	230-240 / 50	230-240 / 50	230-240 / 50	230-240 / 50
Three pin plug type	Amp	10	10	10	10	10	10
Length of power lead	mm	1600	1600	1600	1600	1600	1600
Max. Power Consumption	W	2000	2000	2000	2000	2000	2000
Power for Flame Effect	W	28	40	50	52	62	72

Heat Output	0.9 - 1.8 kW
--------------------	---------------------

Auxiliary Electricity Consumption	W
At Nominal Heat Output	12.5
At Minimum Heat Output	12
In Standby Mode	1.1

Type of Heat Output / Room Temperature Control	Yes / No
With electronic room temperature control	Yes
Electronic room temperature control plus day timer	Yes
Electronic room temperature control plus week timer	Yes

Other Control Options	Yes / No
Room temperature control, with open window detection	Yes
With distance control option	Yes
With adaptive start control	Yes

Warranty

	Product Group	Firebox		All other parts	
		Parts	Labour	Parts	Labour
Residential	Electric Fire Heater	5 Years	2 Years	2 Years	2 Years