

EVOLUTION[®] 100 TECHNOLOGY

Featuring two-stage grinding combined with SoundSeal™ Plus technology, the Evolution 100 is more powerful and quieter than our standard range. It virtually grinds any food waste, including difficult items such as bones and potato peel.

FEATURES



SoundSeal Plus™ Evolution Quieter Technology



0.75HP Dura-Drive™ Heavy Duty Induction Motor



MultiGrind Plus™ 2 Stage Stainless Grinding System with Auto Reverse Action



QuickLock™ Sink Mount for easy installation



Large Capacity (1005ml) Stainless Steel Grinding Chamber



5 Year Warranty



Built-in Air Switch (33mm hole for button)



Made in the USA

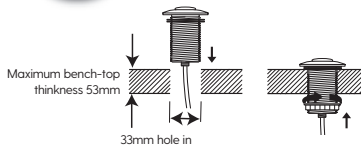

DIMENSIONS (MM)

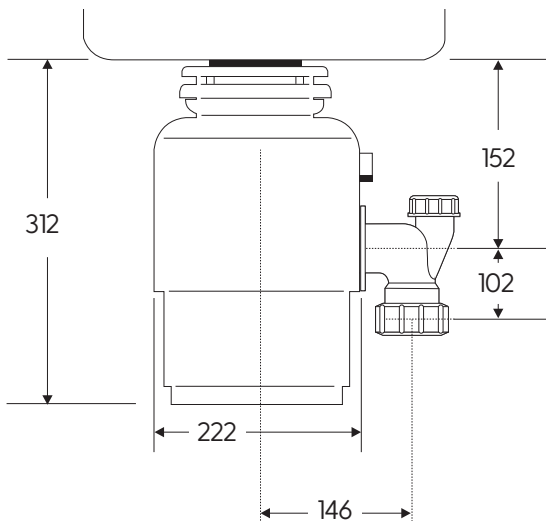

SPECIFICATIONS

Type of Feed On/Off	Continuous Control Wall Switch or Built-In Air Switch	Sound Technology	Anti-Vibration Mounting Technology and Tailpipe Quiet Sink Baffle Multi-Layer Sound Insulation
Power Supply Reversing	Single Phase Auto-Reverse Grind System	Plug	Stainless Steel Strainer Basket and Plug
Time Rating Lubrication	Intermittent Permanently Lubricated Upper & Lower Bearings	Grind Chamber Capacity	1005 ml
Shipping Weight	8.8 kg (Approx.)	Motor Protection	Manual Reset Overload
Unit Finish	Black Enamel Grey TEN-1706	Average Water Usage	Approximately 4.0 L per Person per Day
Overall Height	312 mm	Average Electrical Usage	3-4 KWH per Annum
Grind Technology	2-Stage Grind Technology	Drain Connection	1-1/2" (3.81 cm) Anti-Vibration (Hose Clamp)
		Dishwasher Connection	Yes
Volts/Hz	HP	RPM	
220-240V, 50 Hz	.75	1425	

in sink erator[®]