



Model 46 Food Waste Disposer

The entry level InSinkErator model, suitable for lighter use in smaller households.



Features



Basic Sound Reduction Technology



Air Switch Kit Available
(33mm hole for button)



1 Stage Grinding System



0.55HP Dura-Drive™ Heavy Duty Induction Motor



Grind Chamber Capacity (900ml)



2 Year Warranty



QuickLock™ Sink Mount for easy installation



Made in the USA

Specifications

Type of Feed	Continuous
On/Off	Wall Switch
Power Supply	Single Phase
Time Rating	Intermittent
Lubrication	Permanently Lubricated Upper & Lower Bearings
Grind Technology	1-Stage Grind Technology
Sound Technology	Quiet Sink Baffle Sound Insulation

Grind Chamber Capacity	900 ml
Motor Protection	Manual Reset Overload
Average Water Usage	Approximately 4.0 L per Person per Day
Average Electrical Usage	5-6 KWH per Annum
Drain Connection	1-1/2" (3.81 cm) 40mm Straight Discharge Pipe also included
Dishwasher Connection	Yes

Volts/Hz	220-240V, 50 Hz
----------	-----------------

HP	.55
RPM	1490

Average Load	460 W
--------------	-------

Dimensions (mm)

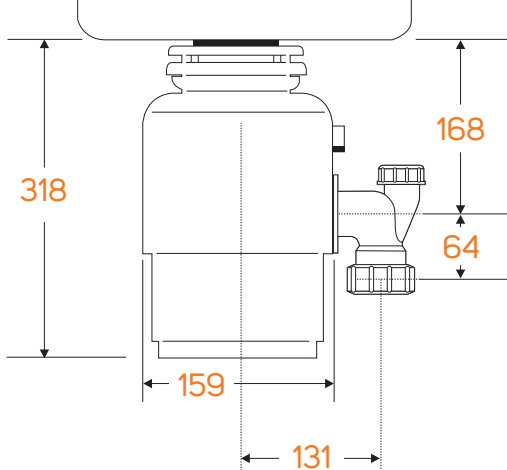

InSinkErator reserves the right to change product specifications without prior notice. The disposer described in this leaflet is for household use; usage in commercial situations is not covered by warranty.

For more information contact Parex Industries Limited on Tel: 0800 200 510 or email info@parex.co.nz

www.insinkerator.co.nz

