

# Model 56

## Food Waste Disposer

This mid-range model is perfect for regular use in smaller households.

### Features



Basic Sound Reduction Technology



0.55HP Dura-Drive™ Heavy Duty Induction Motor



1 Stage Stainless Grinding System



QuickLock™ Sink Mount for easy installation

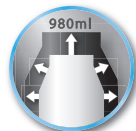

Grind Chamber Capacity (900ml) Stainless Steel Grinding Elements



3 Year Warranty



Built-in Air Switch (33mm hole for button)



Made in the USA

### Specifications

Type of Feed On/Off	Continuous Control Wall Switch or Built-In Air Switch	Grind Chamber Capacity	900 ml
Power Supply	Single Phase	Motor Protection	Manual Reset Overload
Time Rating	Intermittent	Average Water Usage	Approximately 4.0 L per Person per Day
Lubrication	Permanently Lubricated Upper & Lower Bearings	Average Electrical Usage	3-4 KWH per Annum
Grind Technology	1-Stage Grind Technology	Drain Connection	1-1/2" (3.81 cm) 40mm Straight Discharge Pipe also included
Sound Technology	Quiet Sink Baffle Sound Insulation	Dishwasher Connection	Yes
Volts/Hz	HP	RPM	Average Load
220-240V, 50 Hz	.55	1490	460 W

InSinkErator reserves the right to change product specifications without prior notice. The disposer described in this leaflet is for household use; usage in commercial situations is not covered by warranty.

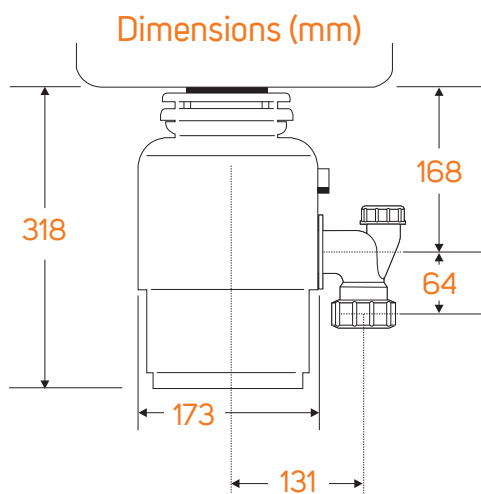

For more information contact Parex Industries Limited on Tel: 0800 200 510 or email [info@parex.co.nz](mailto:info@parex.co.nz)

[www.insinkerator.co.nz](http://www.insinkerator.co.nz)

in sink erator®