

Model 66

Food Waste Disposer

The top model in our standard range, offering high performance, continuous feed operation and able to handle a wide variety of food waste.

Features



Basic Sound Reduction Technology



0.75HP Dura-Drive™ Heavy Duty Induction Motor



1 Stage Stainless Grinding System



QuickLock™ Sink Mount for easy installation

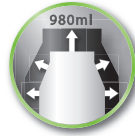

Grind Chamber Capacity (900ml) Stainless Steel Grinding Elements



4 Year Warranty



Built-in Air Switch (33mm hole for button)



Made in the USA

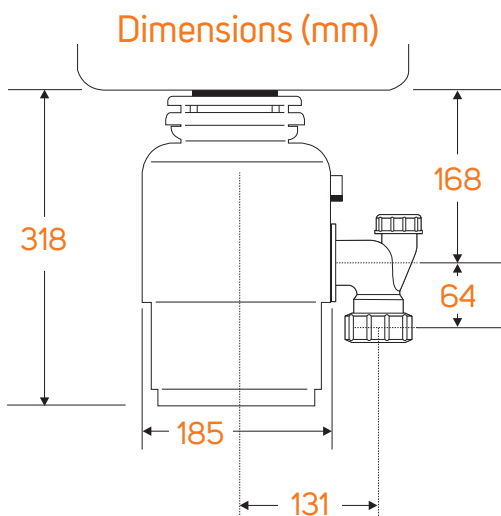

Specifications

Type of Feed	Continuous	Grind Chamber Capacity	900 ml
On/Off	Control Wall Switch or Built-In Air Switch	Motor Protection	Manual Reset Overload
Power Supply	Single Phase	Average Water Usage	Approximately 4.0 L per Person per Day
Time Rating	Intermittent	Average Electrical Usage	5-6 KWH per Annum
Lubrication	Permanently Lubricated Upper & Lower Bearings	Drain Connection	1-1/2" (3.81 cm) 40mm Straight Discharge Pipe also included
Grind Technology	1-Stage Grind Technology	Dishwasher Connection	Yes
Sound Technology	Quiet Sink Baffle Sound Insulation		
Volts/Hz	HP	RPM	Average Load
220-240V, 50 Hz	.75	1490	500 W

InSinkErator reserves the right to change product specifications without prior notice. The disposer described in this leaflet is for household use; usage in commercial situations is not covered by warranty.

For more information contact Parex Industries Limited on Tel: 0800 200 510 or email info@parex.co.nz

www.insinkerator.co.nz

