

# SEPTIC2000

## FOOD WASTE DISPOSER

The SEPTIC2000 with its three stage grind technology is perfect for use with a properly sized septic tank. Soundseal™ plus, makes it our quietest model. Don't worry about what you can and can't grind. The SEPTIC2000 grinds it all!



### FEATURES



#### **.75 Horsepower™ Motor**

The InSinkErator Dura-Drive motor is one of the most powerful and reliable on the market.



#### **Built-In Air Switch**

All InSinkErator's use air to turn the disposer on and off, making it safe around electricity.



#### **Multigrind Plus™ 3 Stage Grinding**

MultiGrind Plus™ 3 Stage Stainless Grinding System with Auto Reverse Action. This grinds the food waste into tiny particles that can easily be broken down in a septic system.



#### **Soundseal Plus™ Noise Reduction**

Makes the SEPTIC2000 the quietest on the market.



#### **Largest Stainless Steel 1180ml Grind Chamber**

Largest capacity of any domestic disposer on the market.



#### **Quicklock™ Sink Mount**

Makes it easy to install into the sink, and come with all models.



#### **Made In The USA**



#### **10 Year Warranty**

The SEPTIC 2000 comes with a 10 year in-home warranty.

### SPECIFICATIONS

<b>Type of Feed On/Off</b>	Continuous Control Wall Switch or Built-In Air Switch	<b>Sound Technology</b>	Anti-Vibration Mounting Technology and Tailpipe Quiet Sink Baffle Multi-Layer Sound Insulation Stainless Steel Strainer Basket and Plug
<b>Power Supply Reversing</b>	Single Phase Auto-Reverse Grind System	<b>Plug</b>	Stainless Steel Strainer Basket and Plug
<b>Time Rating Lubrication</b>	Intermittent Permanently Lubricated Upper & Lower Bearings	<b>Grind Chamber Capacity</b>	1180 ml
<b>Shipping Weight Unit Finish</b>	11.6 kg (Approx.) Stainless Steel Light Grey TEN-1706	<b>Motor Protection</b>	Manual Reset Overload
<b>Overall Height Grind Technology</b>	344 mm 3-Stage Grind Technology Power Booster Circuit with Microprocessor	<b>Average Water Usage</b>	Approximately 4.0 L per Person per Day
<b>Volts/Hz</b>	220-240V, 50 Hz	<b>Average Electrical Usage</b>	3-4 KWH per Annum
<b>HP</b>	.75	<b>Drain Connection</b>	1-1/2" (3.81 cm) Anti-Vibration (Hose Clamp)
<b>RPM</b>	1425	<b>Dishwasher Connection</b>	Yes

#### DIMENSIONS (MM)

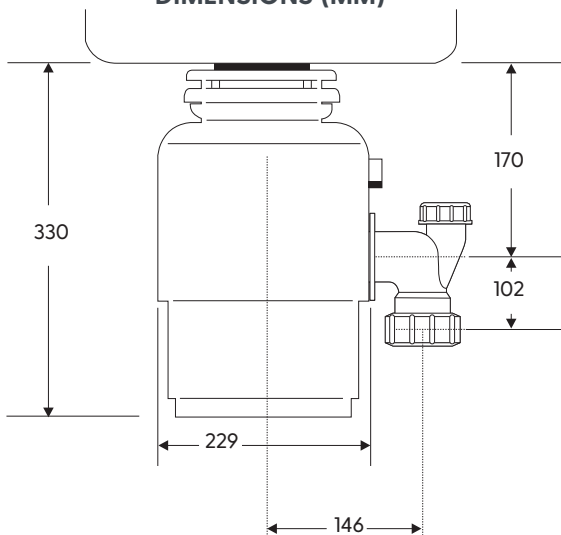

inSinkErator®