



STANDARD SERIES

Standard 460 SR

Benefits

This model offers the following benefits:

- Food waste is ground into particles and flushed away
- A convenient solution to food waste in the home
- Lift & Latch Technology makes it easy to install into new or existing kitchens and can be fitted to most sinks
- Space-Saving compact design
- By using your disposal regularly, you can help divert food waste from landfills and reduce greenhouse gas emissions.

Features

This model offers the following features:

- **0.55 HP induction motor** provides maximum grinding power and durability
- **Single Stage Grind Technology**
- Air switch - Additional Kit Available to Purchase.

Warranty

2-Year In-home Warranty

Specifications

Type of Feed	Continuous
On/Off Control	Air Switch Kit Available
Motor	Single Phase
Motor HP	0.55
Volts	220-240
HZ	50-60
Motor Power, W	380 W
Time Rating	Intermittent
Lubrication	Permanently Lubricated Upper & Lower Bearings
Shipping Weight (Approx.)	7.7 kg
Overall Height	31.2 cm
Motor Protection	Manual Reset
Drain Connection	3.8 cm Cushioned Slip Joint
Dishwasher Drain Connection	No
Grind Technology	Single Stage Grind
Plug	10 amp plug
Grind Chamber Capacity	980 ml

Dimensions

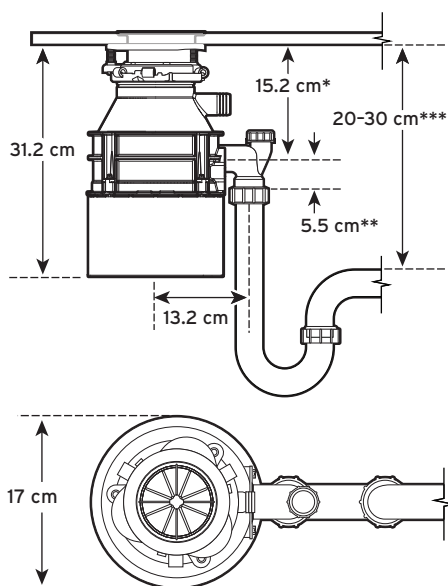

*Distance from bottom of sink to centre line of disposer outlet. Add 12.7 mm when stainless steel sinks are used.

**Length of tailpipe from centre line of disposer outlet to end of tailpipe.

***Distance between bottom of sink bowl to the waste pipe to be minimum of 30 cm.

