



MODEL 66

FOOD WASTE DISPOSER

The top model in our standard range, offering high performance, continuous feed operation and able to handle a wide variety of food waste.

FEATURES



SoundSeal Plus™
Quieter than
standard models



0.75HP Dura-Drive™
Heavy Duty
Induction Motor



1 Stage Stainless
Grinding System



QuickLock™
Sink Mount for
easy installation



Grind Chamber
Capacity (980ml)
Stainless Steel
Grinding Elements



4 Year Warranty



Built-in Air Switch
(33mm hole for button)



Made in the USA

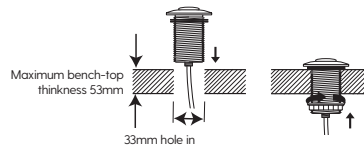

DIMENSIONS (MM)

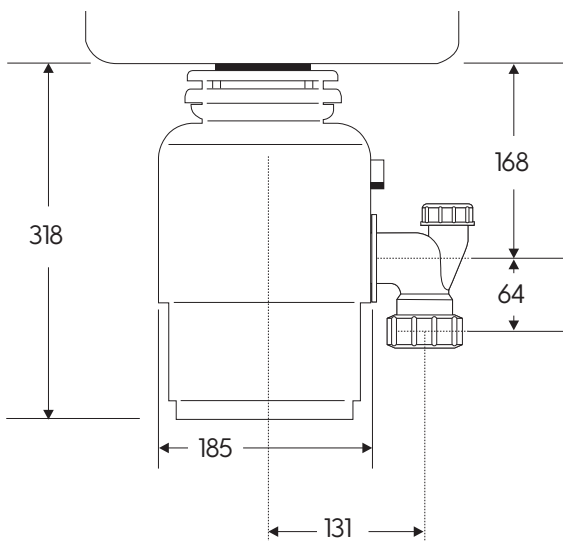

SPECIFICATIONS

Type of Feed	Continuous	Grind Chamber Capacity	980 ml
On/Off	Control Wall Switch or Built-In Air Switch	Motor Protection	Manual Reset Overload
Power Supply	Single Phase	Average Water Usage	Approximately 4.0 L per Person per Day
Time Rating	Intermittent	Average Electrical Usage	5-6 KWH per Annum
Lubrication	Permanently Lubricated Upper & Lower Bearings	Drain Connection	1-1/2" (3.81 cm)
Grind Technology	1-Stage Grind Technology	Dishwasher Connection	Yes
Sound Technology	Quiet Sink Baffle Sound Insulation		
Volts/Hz	HP	RPM	
220-240V, 50 Hz	.75	1490	

in sink erator®