

SPECIFICATION SHEET

Atlanta 1700 Drop-in-Bath

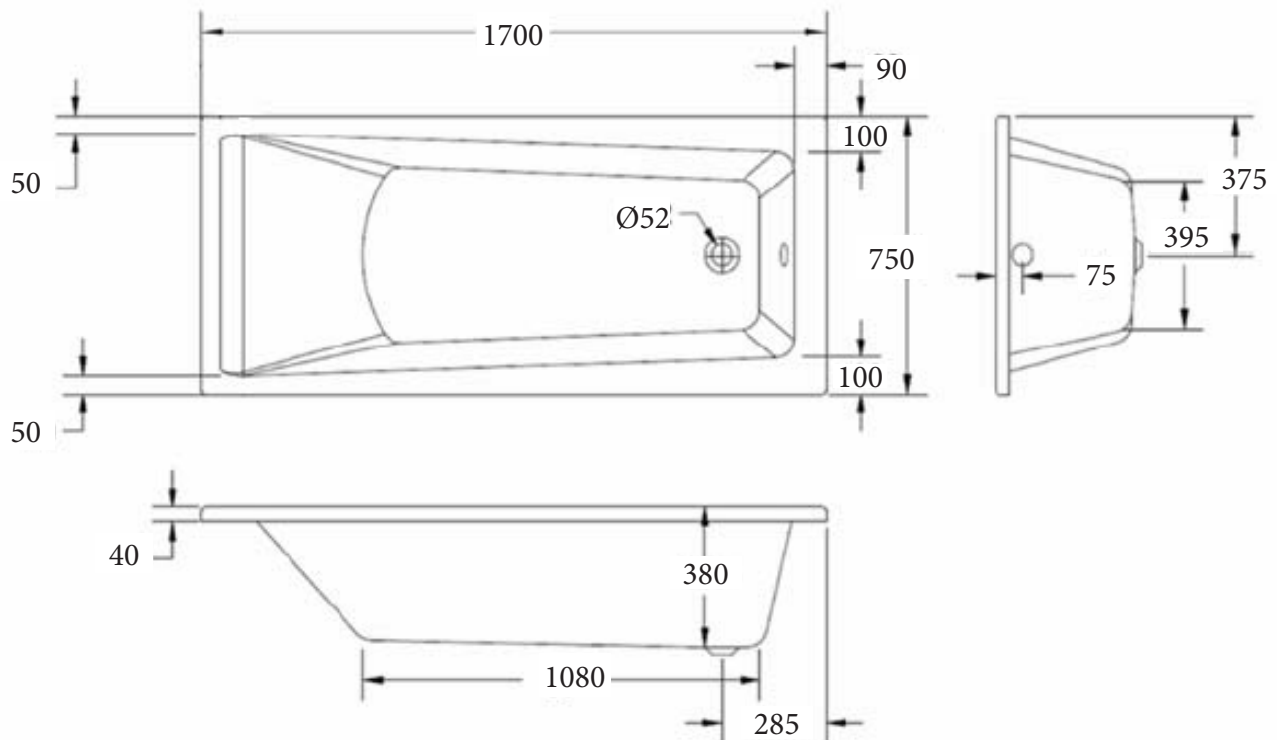

| | |
|-----------|---------------------------|
| Product: | Atlanta 1700 Drop-in-Bath |
| Size: | L1700 X W750 X D380 |
| Capacity: | 159 Litres |
| Weight: | 17.5KG |

*Disclaimer: Measurements are nominal.

© 2016 Newtech. All rights reserved.