

FRONT FLUSH MECHANICAL 90MM INWALL CISTERN

PA110

PARISI

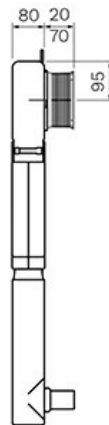
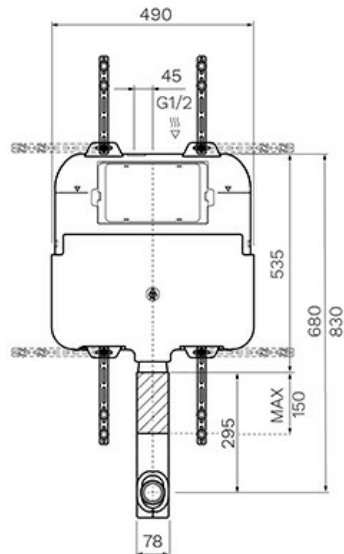

Residential/Light Commercial Use

Suitable for Residential/Light Commercial Use (Kitchens, Bathrooms and Laundries in Hotels, Motels and Retirement Villages).

15

Guarantee

15 Year Guarantee



Additional Information

The bracket should be mounted flush with the timber framing so the Villa board will be hard against the bracket. NB failure to do this may cause the wall to move and tiles to crack.



Additional Information

If necessary strengthen the wall using additional horizontal or vertical nogs and also additional fixings at floor and ceiling.





Additional Information

Once the Bracket has been installed, the wall framing should be tested for any deflection. There should not be any deflection.



Additional Information

The Wall Studs should be nogged in a minimum of three places spaced equally between floor and ceiling.



Additional Information

The minimum size of Timber framing and Grade is 100mm x 50mm Radiata MSG8, K/D, H1.2, M/g



Additional Information

The Top and Bottom Timber Framing Plates must be well secured with no movement.



Additional Information

If using a wall hung pan the wall lining must be a material such as Villa board with a minimum thickness of 9mm.

The Inwall Concealed Cistern (Mechanical) PA110 is suitable for use with any PARISI wall faced pan. It also provides front actuation push plate access and adjustable height.

Compatible button options are the BLADE and TONDO Collections.